



# Resume + Portfolio

Glenn Veigas

# Melvin Glenn Veigas

Vancouver, British Columbia

veigas.glenn@gmail.com

+(1) 515-509-9563

NCARB - AXP(AIBC) : In-process

## Experience.

**Public, Vancouver.** Intern Architect, November 2019 - Current

Led design development of Kimberly water treatment plant. Led detail design for SFU Burnaby student housing.

**Simon Fraser University Student Housing, 194, 000 SF**

Design Development & Detail Design.

Work-flow: Revit, Rhino, Grasshopper, Photoshop, Illustrator

**LMN Architects, Seattle.** Design Staff, May 2017 - Sep 2017

Conducted firm wide sustainability research on multiple projects, calculating carbon footprint, researching rainwater harvesting details, post-occupancy research, and energy modelling.

**BNIM, Des Moines.** Architectural Designer, Sep 2015 - Apr 2016

Designed conceptual and design details for institutional and cultural projects.

**University of Iowa Stanley Art Museum, 72, 000 SF**

Conceptual Design, Design Development & Detail Design.

Work-flow: Revit, Rhino, Photoshop, Illustrator, 3D Printer, Laser Printer

**University of Iowa Visual Arts Building, 126, 000 SF**

2017 AIAANY Honor Award

Construction Documents, Work-flow: Revit, AutoCad

**Stevanovich Institute on the Formation of Knowledge, 11, 400 SF**

Detail Design, Work-flow: Revit, SketchUp, AutoCad

**Iowa State University Innovation Center - Invited Competition, 140,000 SF**

Conceptual Design, Work-flow: Rhino/Grasshopper, 3D Printer, Illustrator

**SVPA Architects, Des Moines.** Intern Architect, Jan - August 2015

Designed conceptual and design details for Drake University's school of education. Developed digital renders, digital models & detail drawings.

**Drake School of Education, 45,000 SF**

Conceptual Design, Design Development, Interior & Detail Design

Work-flow: Rhino, 3DS Max, V-Ray, Photoshop, Illustrator

**White Young Architects, Qatar.** Intern Architect, May - August 2013

Crafted conceptual renders and diagrams for multi-family residence, design details for private residence, interfaced with clients, engineers, consultants & reviewed shop drawings.

**Jaidha Residence, 11,000 SF**

Design Development & Detail Design Work-flow: AutoCad, 3DS Max/V-Ray

**Dar Al Handassah Consultants, Qatar.** Site Architect-Medina Centrale, Feb - Sep 2011  
Reviewed construction & shop drawings, coordinating & Executing architectural works & finishes. Interfaced with construction managers & structural engineers.

Medina Centrale, 300,000 SF  
Contract Documents, Site Inspection

## Education.

### M. Sc. Arch

Iowa State University  
College of Design  
Ames, Iowa, U.S.A.  
2016 - 2019

### M. Arch

Iowa State University  
College of Design  
Ames, Iowa, U.S.A.  
2012 - 2015

### B. Arch

National Institute of Technology  
Department of Architecture  
Tamil Nadu, India  
2005 - 2010

## Awards.

ARCC King Medal -For Excellence in Architectural + Environmental Research	2019
Second, All India Design Competition	2007

## Service.

Graduate senator, Iowa State University	2014
Master of ceremony, Design convention	2009
President, Architectural Student Association	2008

## References.

**John Wall, Principal, Architect AIBC, MRAIC, PUBLIC Vancouver**  
john@publicdesign.ca      604-340-3169  
1495 Frances st Vancouver BC, V5L 1Z1

**Carey Nagle, Associate Principal, BNIM Des Moines**  
cnagle@bnim.com      515.559.0424  
317 6th Ave #100, Des Moines, IA 50309

**Sam Miller, FAIA, LEED AP, Partner, LMN Architects, Seattle**  
smiller@lmnarchitects.com      206 682 3460  
801 2nd Avenue, Suite 501 Seattle, WA 98104

**Ulrike Passe, Associate Professor, Iowa State University**  
Director. Centre for Building Energy Research,  
upasse@iastate.edu      515- 294- 7142  
158 College of Design Ames. IA . 50011



At BNIM architects, I was part of team of 6 designers led by Carey Nagle working on a museum in the state of Iowa. The art museum was sanctioned by a liberal arts college to collate and curate their extensive collection which was spread over multiple buildings. It was the university's intent to formalize their collection in a space with permanent and rotating galleries as well as learning classrooms. I worked on conceptual spatial design, and was in charge of developing details relating to solar shading, vertical circulation and wall assembly, modelling and visualization both digital and physical and, structural/mechanical coordination.



**BNIM Architects, Des Moines.**  
**Stanley Museum of Art, Architectural Designer**



The design is square in plan with a courtyard carved out to serve as an ambulatory element to circulate around and help people position themselves within the building. Apertures and Glazing are used to craft views and daylight the entrance lobby, crafting a relationship between the courtyard and the surrounding context. Programmatically the museum is split over three levels with the reception lobby, learning classroom and service on the 1st floor, the galleries on the second floor and the collections storage, offices, collaborative space and terraces on the third floor. The team went with long format black brick around the north, east and south side create a uniform façade to allow the courtyard beyond to shine through to the street and invite people into the museum.





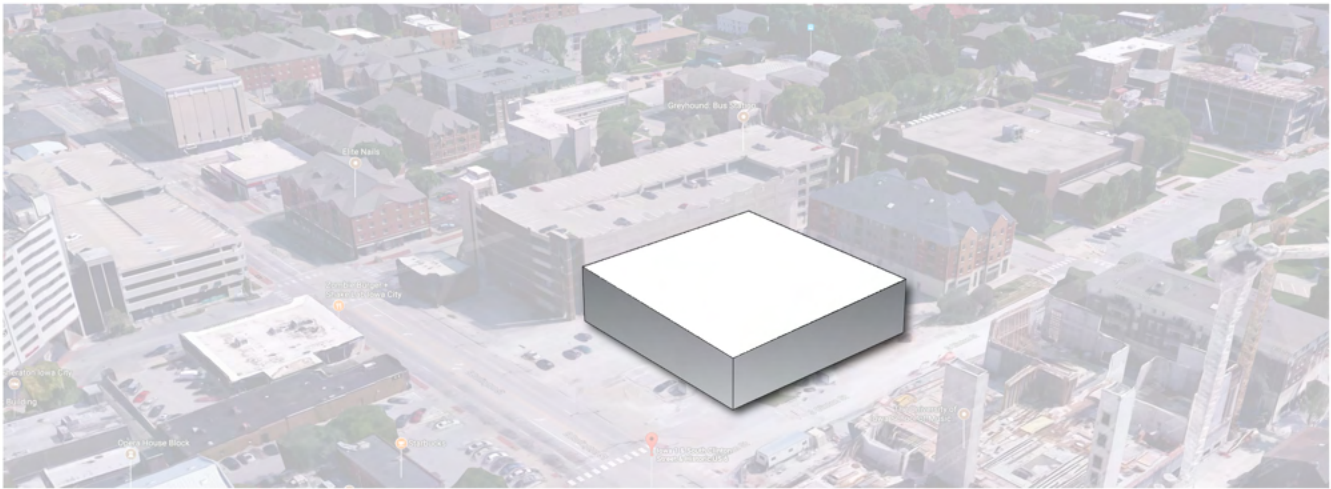

Corner Plot

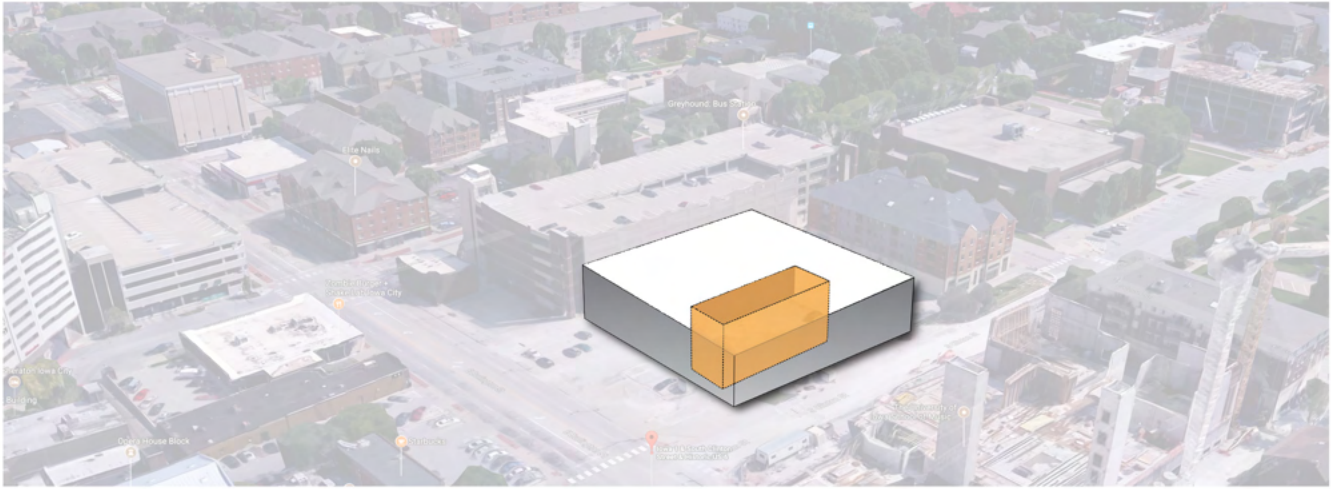

Courtyard



Carve

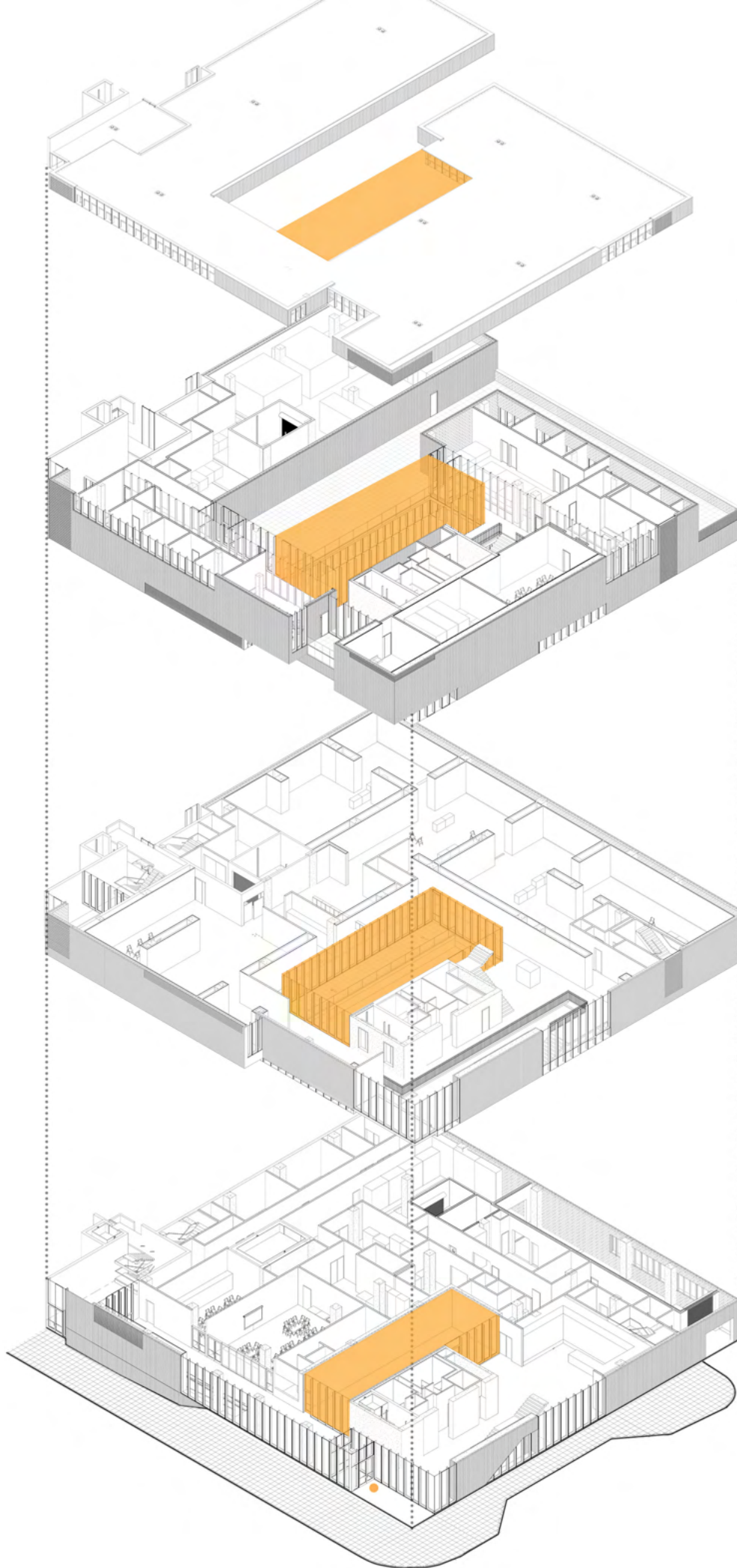

Floor Plans

▲ N

■ Courtyard

● Entrance

3rd Floor  
Art Storage+ Courtyard  
Offices + Classrooms

2nd Floor  
Art Galleries + Courtyard

1st Floor  
Entrance Lobby + Courtyard  
Classroom + Service



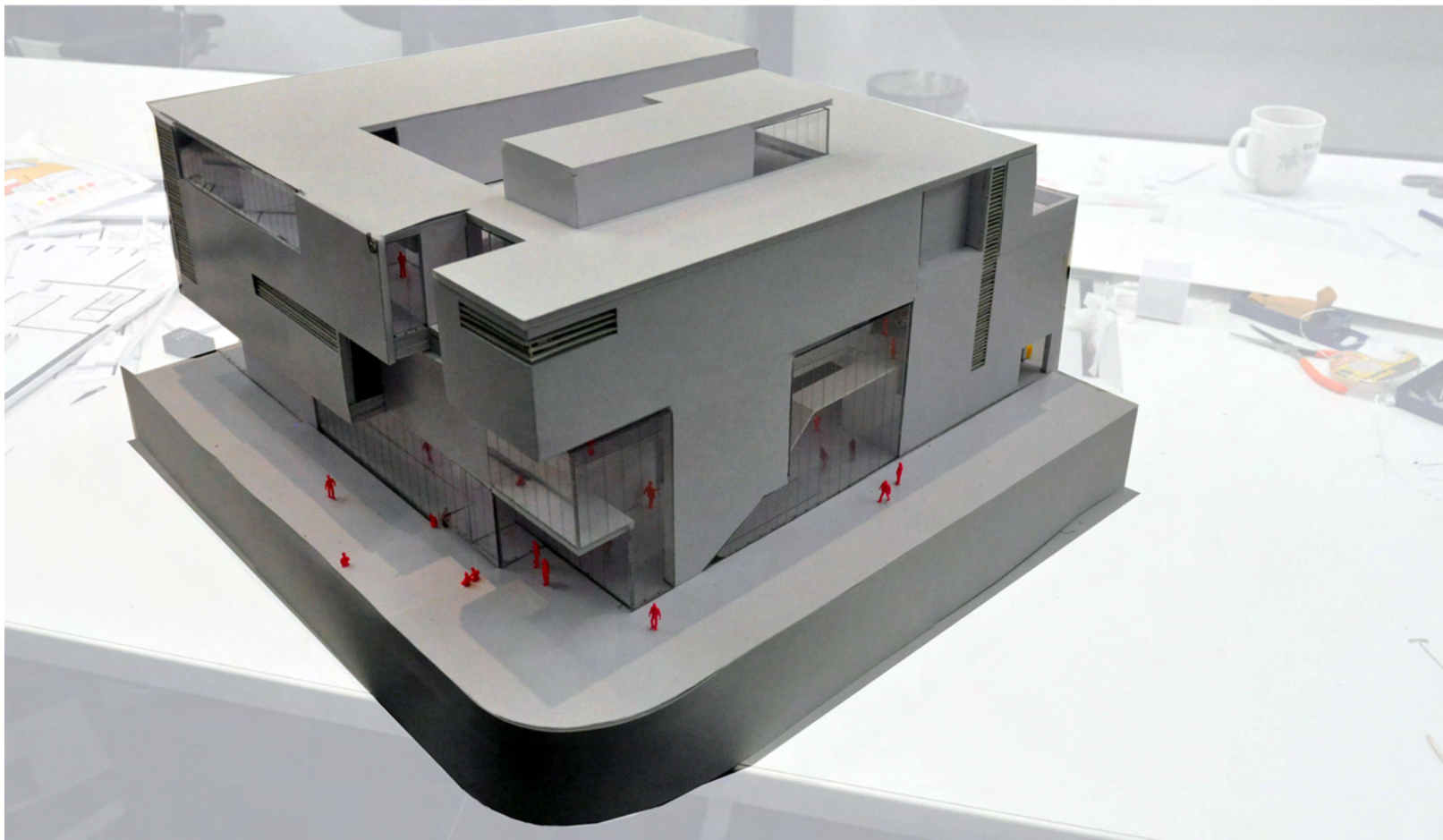
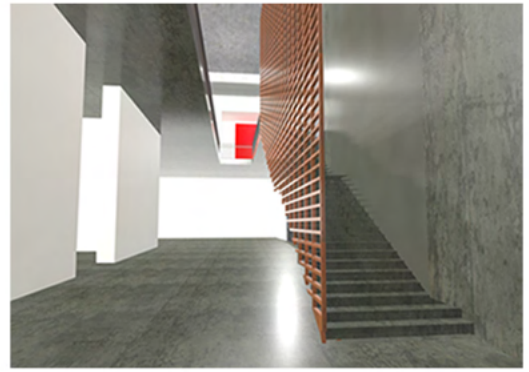



Technical Drawings, Vertical Circulation-Stanley Museum of Art

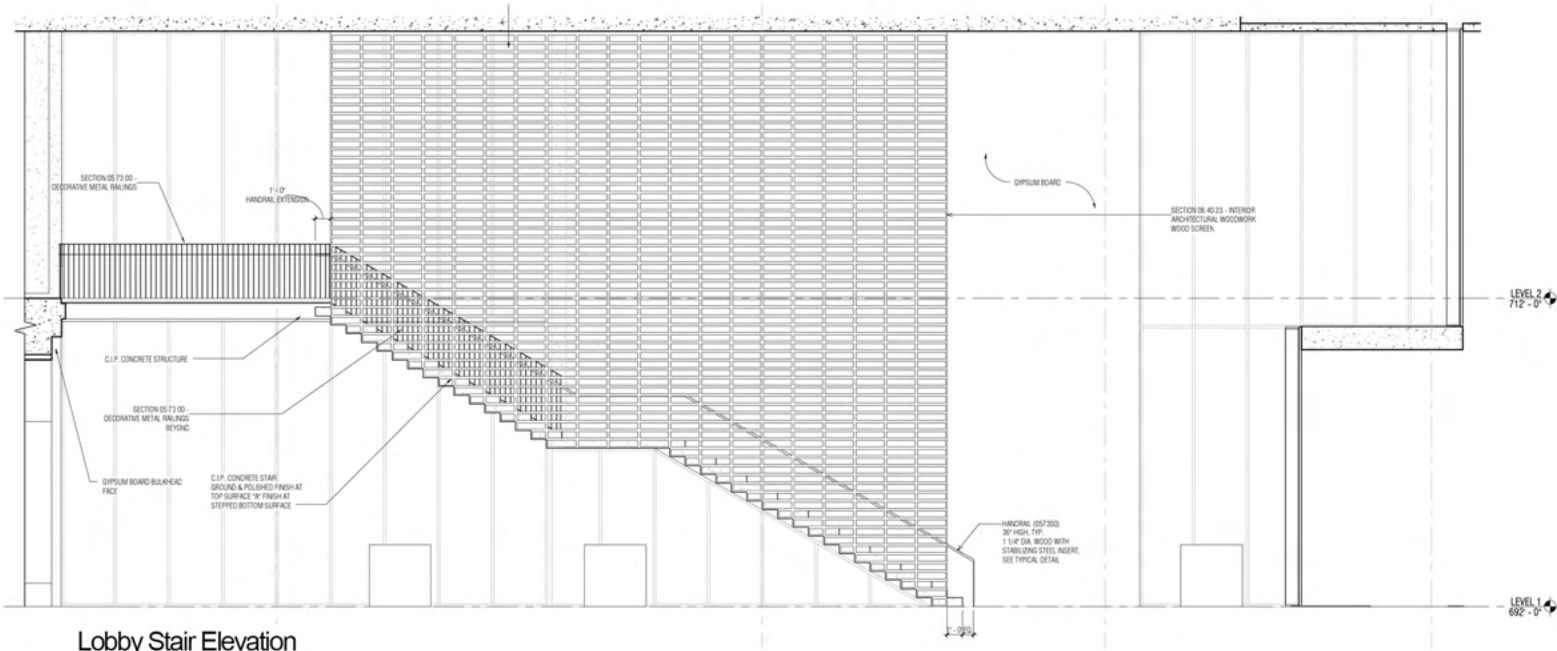

Lobby Stair Elevation

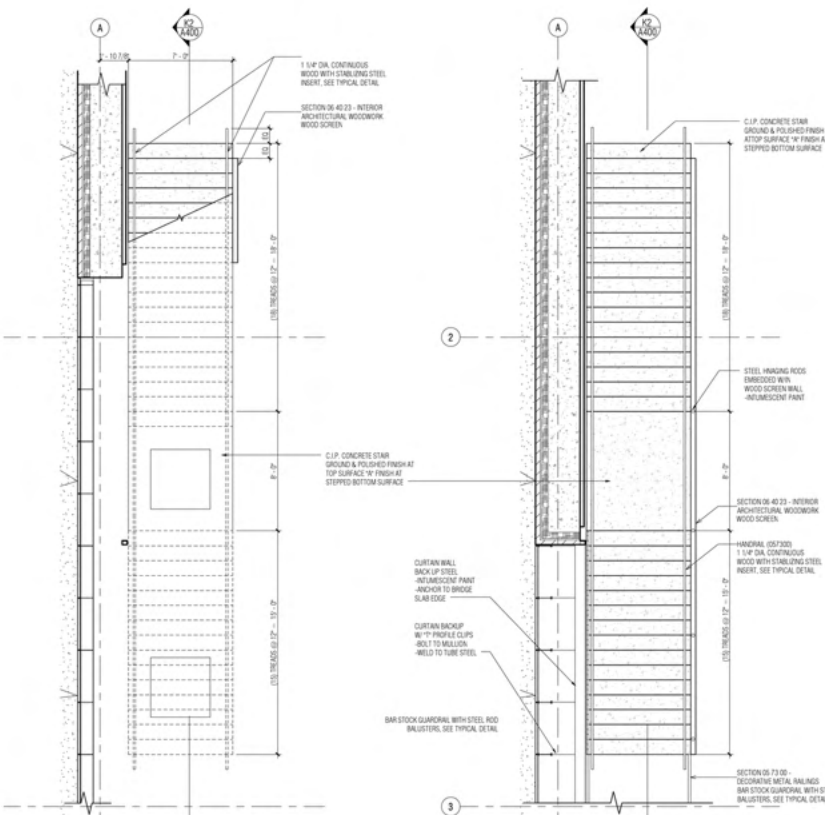

Lobby Stair Level - 1

Lobby Stair Level - 2

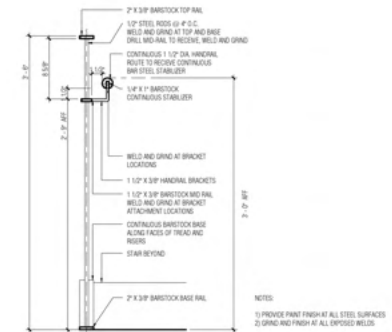

Guardrail and Handrail Detail

NOTES:  
 1. PRIMER PAINT FINISH AT ALL STEEL SURFACES  
 2. SPIND AND FINISH AT ALL EXPOSED WELLS

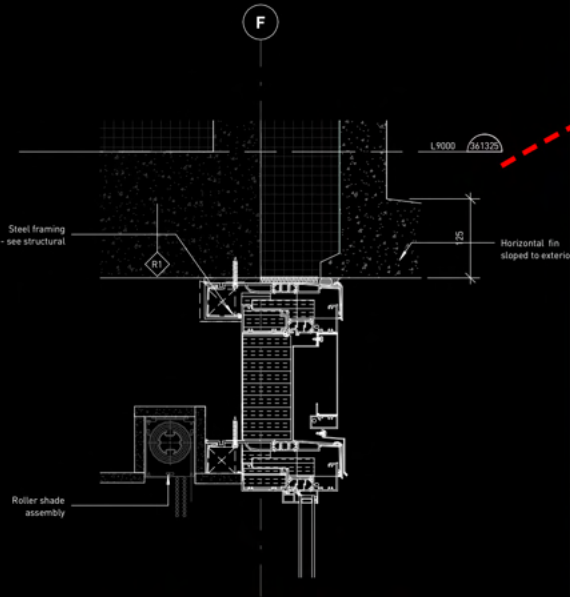

**Window wall head detail**

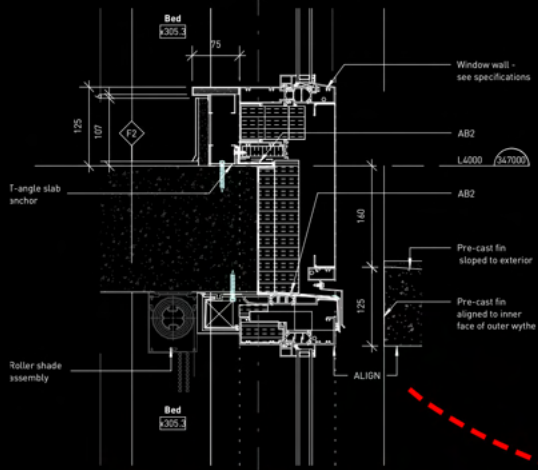

**Window wall slab edge detail**

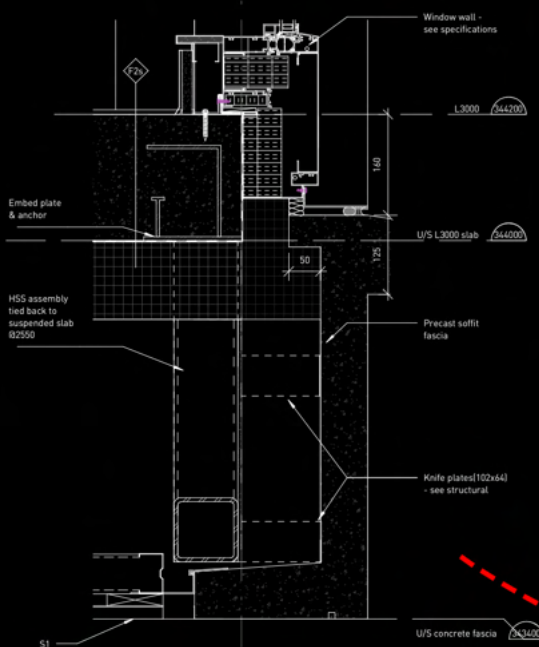

**Window wall soffit transition detail**







At Public design I was part of a team of eight designers working on student housing at Simon Fraser University. The project sits at the north -west section of the Burnaby campus. The three block, 8 - storey structure is part of the University's long term master plan of creating an axial order with the plaza at the eastern end.

Majority of the programmatic spaces are composed of multiple four bedroom and studio spaces on the upper levels. The entry level is composed of private townhouses, social, amenity, and utilitarian spaces.

The program is structured by the formalist logic of cast-in-place column and slabs. The structure is then infilled with precast panels and window wall systems. The structural formalism aligns with the university's aim of respecting Arthur Erickson's vision.

**PUBLIC design, Vancouver.**  
**SFU Student Housing, Architectural Designer**



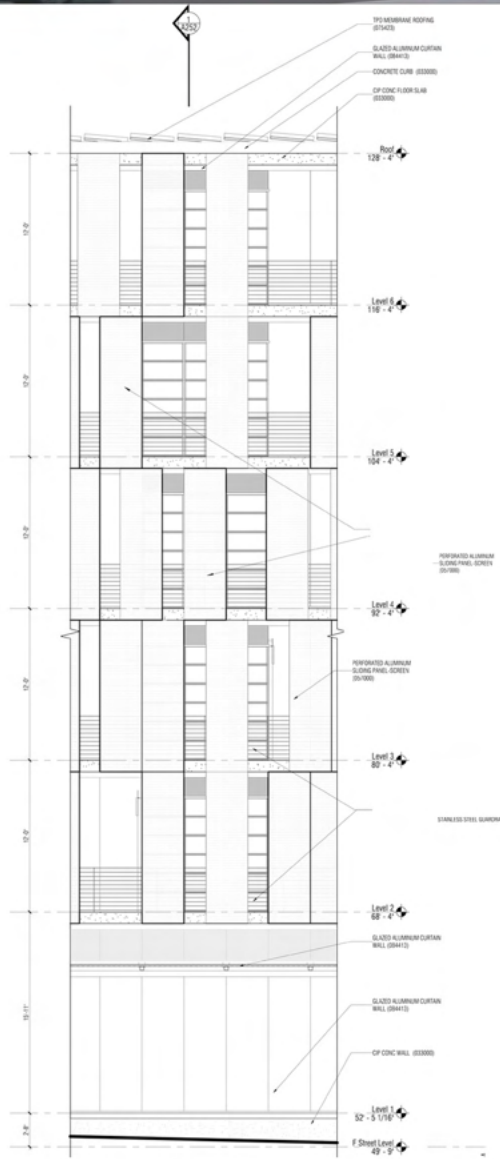

**4** West Wall Enlarged Elevation1

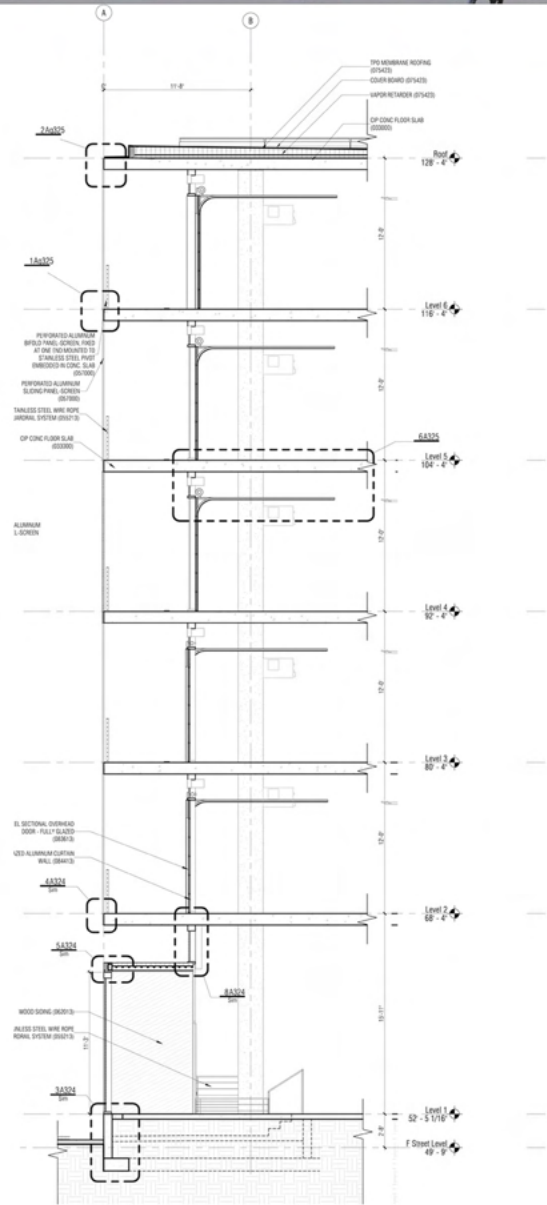

**3** West Garage Door Wall Section



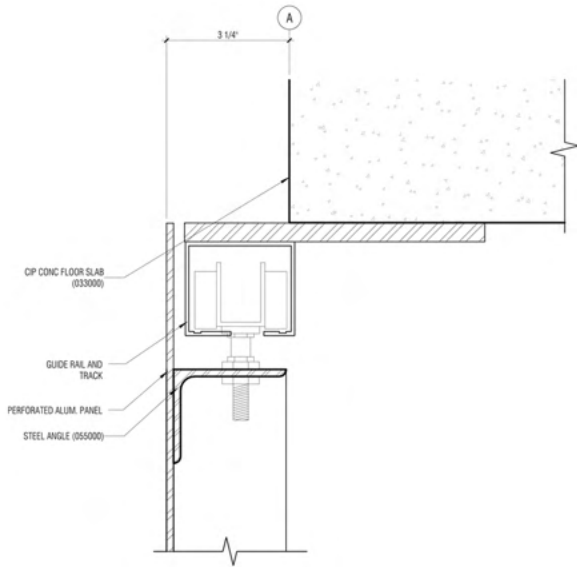

6 Steel Channel Details @ Roof Edge

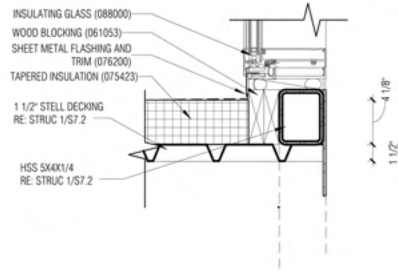

8 Head Detail @ Boxes

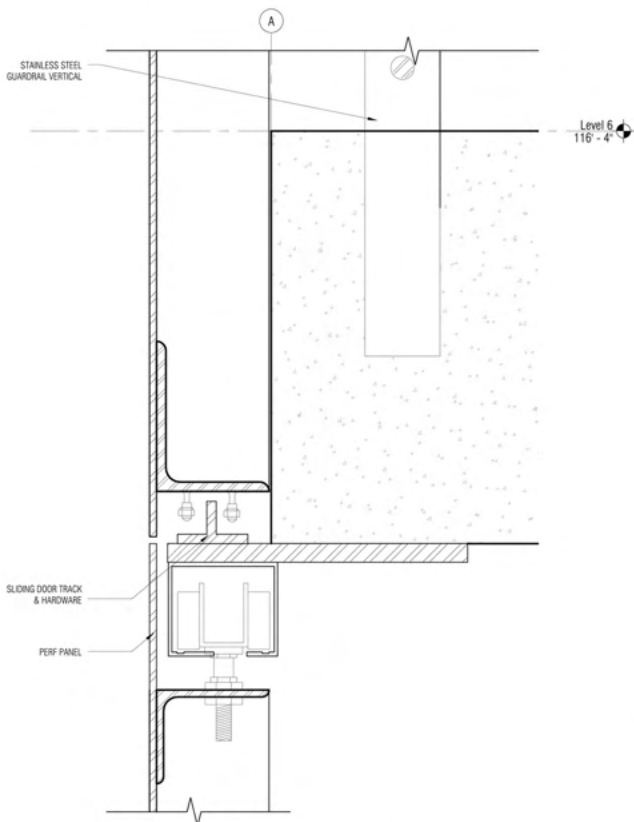

7 Steel Channel @ Operable Panel

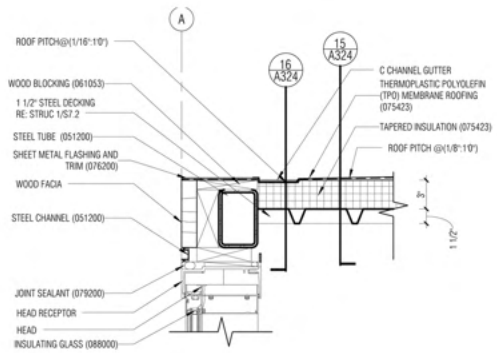

5 Structural Attachment Detail @ Ground Level Boxes

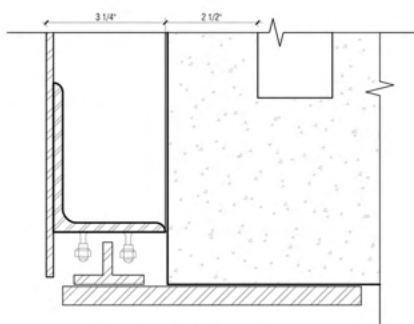

9 Bottom Steel Channel @ Operable Panels

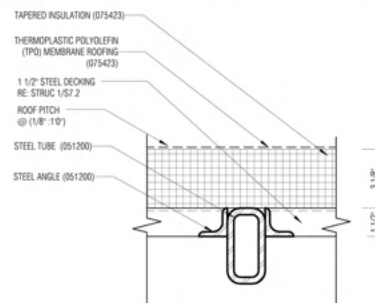

15 Roof Section @ Ground Level Boxes

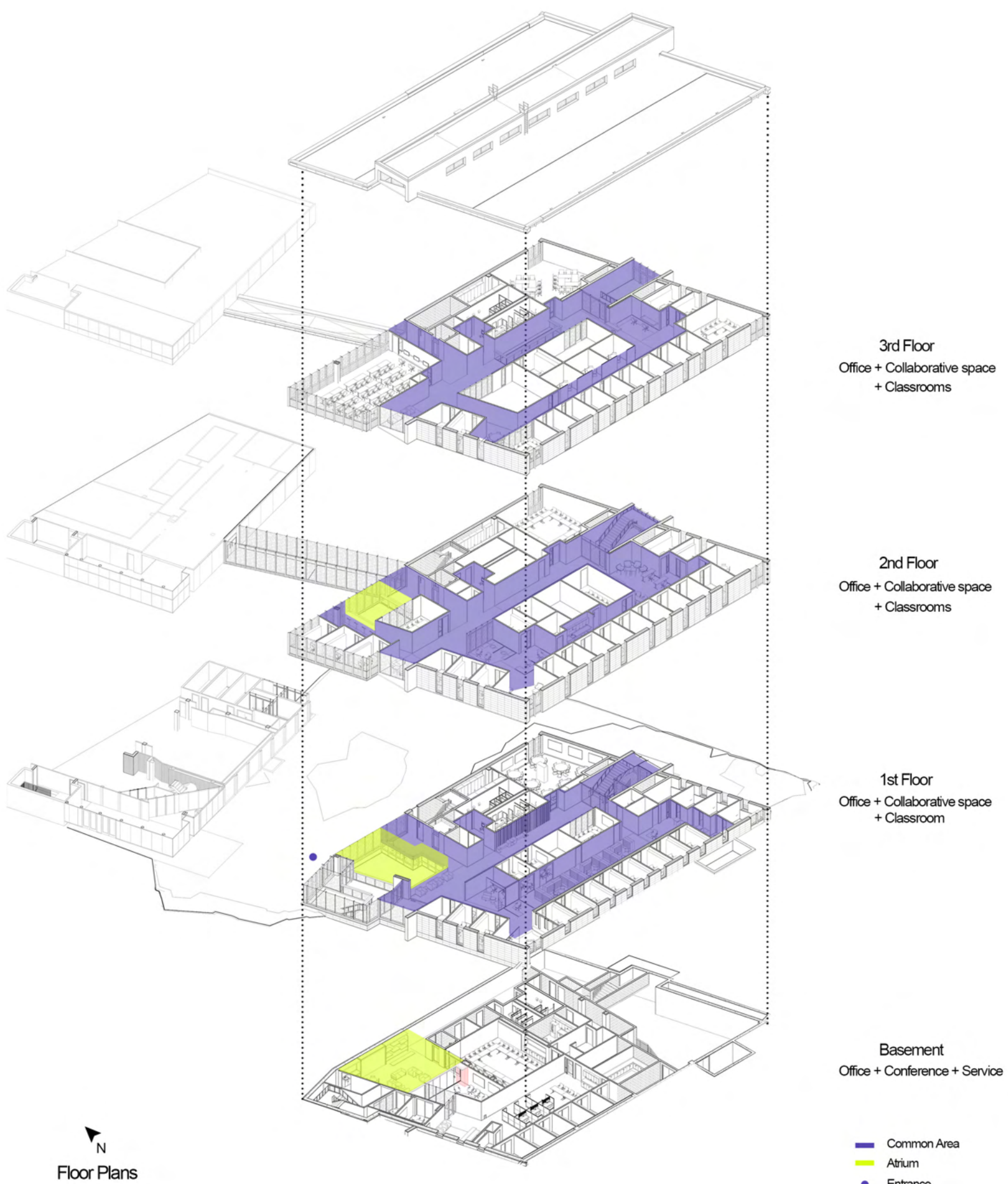

**3rd Floor**  
Office + Collaborative space  
+ Classrooms

**2nd Floor**  
Office + Collaborative space  
+ Classrooms

**1st Floor**  
Office + Collaborative space  
+ Classroom

**Basement**  
Office + Conference + Service

- Common Area
- Atrium
- Entrance



## SVPA Architects, Des Moines.

### Drake School of Education, Intern Architect

At SVPA architects, I worked on Drake University's college of education in Des Moines. The building will sit right across Scott Chapel encompassing 44,500 sq. ft.

I worked on conceptual and detail design, material selection and refinement, leading development and detailing of the rain screen and glazing development, 3d modelling and visualizations for conceptual development and presentations, spatial development and furniture selection and layouts.

The school of education is a building that will fit the need for educational training by providing dedicated flexible space for experimental learning and collaborative spaces as a means of developing future teachers & professors.

In plan it's a parallelogram that is shaped by the interior circulation and spaces responding to street conditions of the west side and leading into the east end creating a spatial enclosure that the university hopes will cultivate informal collaborations.

The material used for the cladding is terracotta and is applied keeping in mind the colour palette and material choice of the existing campus which is brick. The terracotta is realized where most of the spaces require greater privacy like the administrative offices.





**Comprehensive Studio, Iowa State University**

**Center for Performing Arts, Chicago**

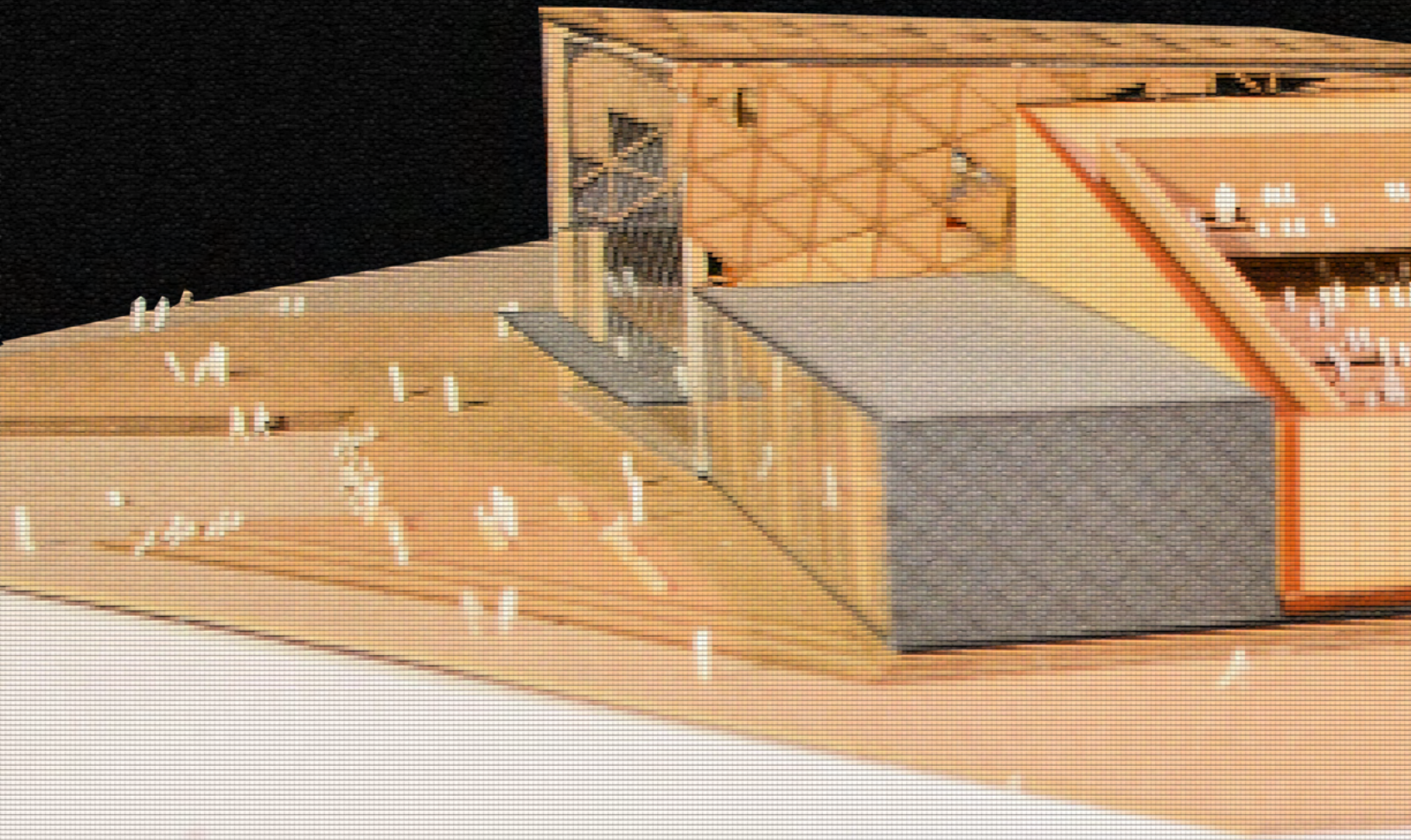



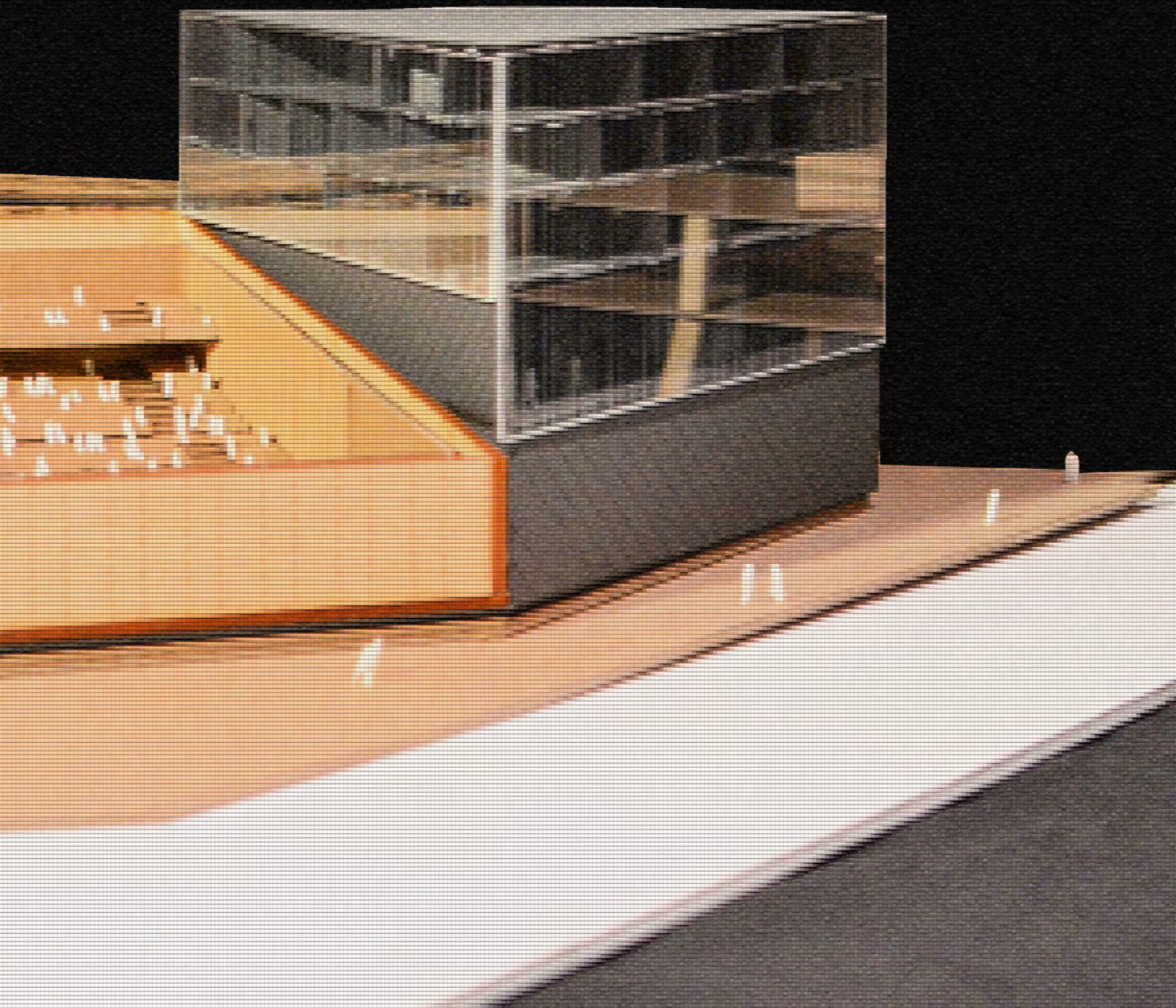







## Comprehensive Studio, Iowa State University

### Centre for Performing Arts, Chicago

The experience is coordinated in a way to create a formal order, towards the openness of the lake. The largest of the two performance halls is zoned adjacent to the atrium and the experimental hall is zoned directly opposite the main performance space. A straight run staircase and landing infill between the two halls connecting them visually and spatially.

The atrium is spanned by an aluminium frame forming a diagrid pattern. The triangular patterns host three panel types, glazing panels for daylight, HVAC panels for venting or trapping heat in the atrium and opaque panels. These three panel types work in conjunction to regulate temperature, daylight and acoustics in the atrium. The second floor frames the view of the lake through the atrium.

This semester long project was designed and executed by two team members, with me spearheading, conceptual design, development of the wall assembly and glazing, thermal and sound calculations, 3d printing and laser cutting, digital and physical representations. The project brief called for a multi-program performance space situated on the banks of the lake adjacent to lake shore drive. The spaces are oriented to form an orchestrated circulation path from, lake shore drive towards the lake.

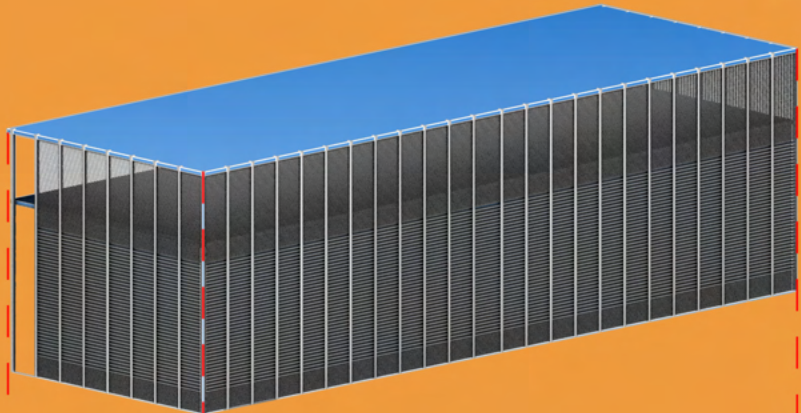

Cafe + Event Space

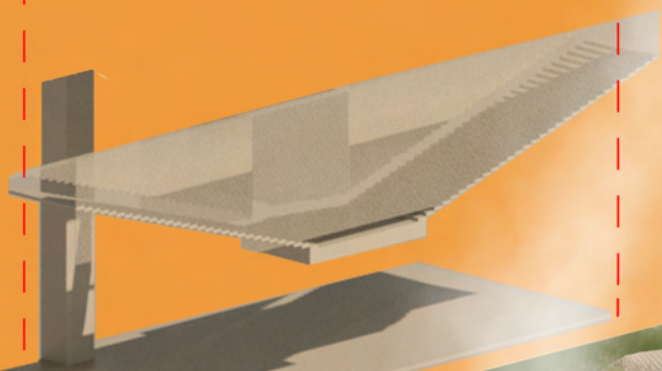

Parklet

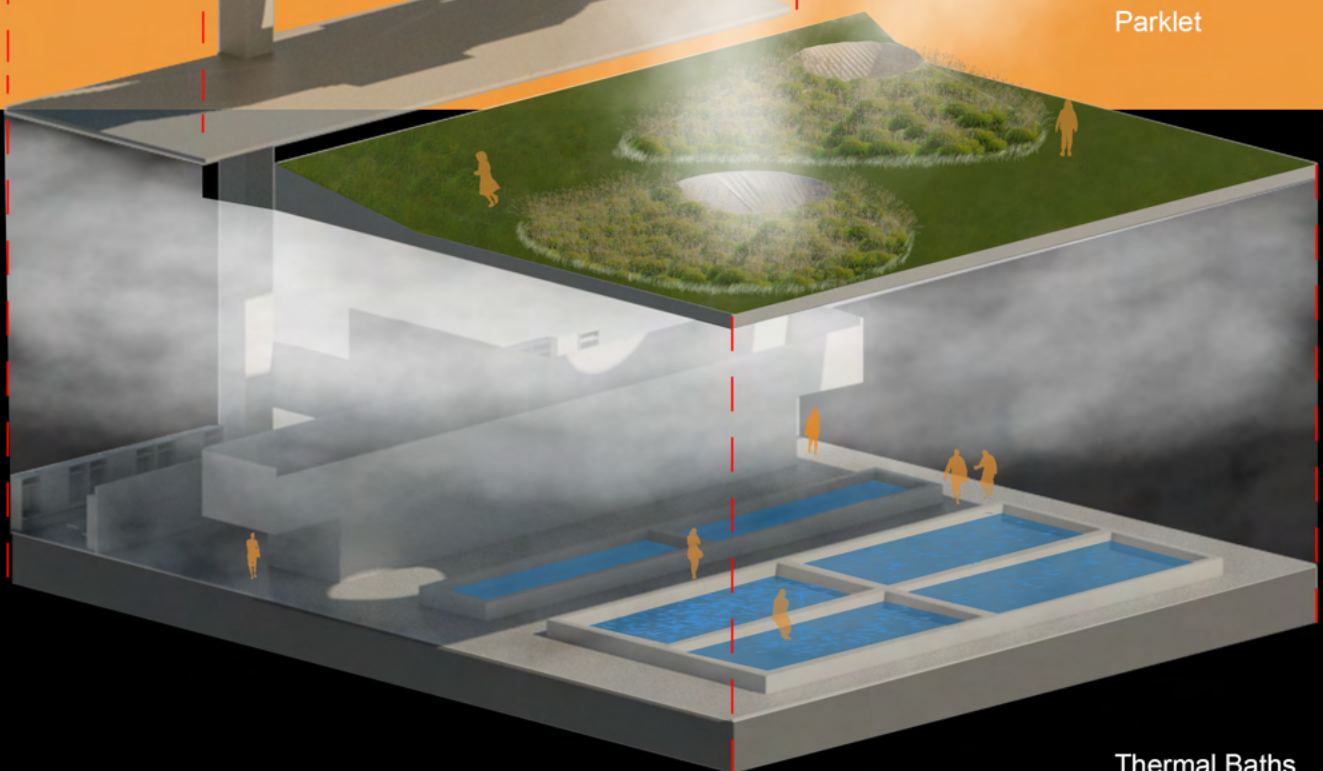

Thermal Baths



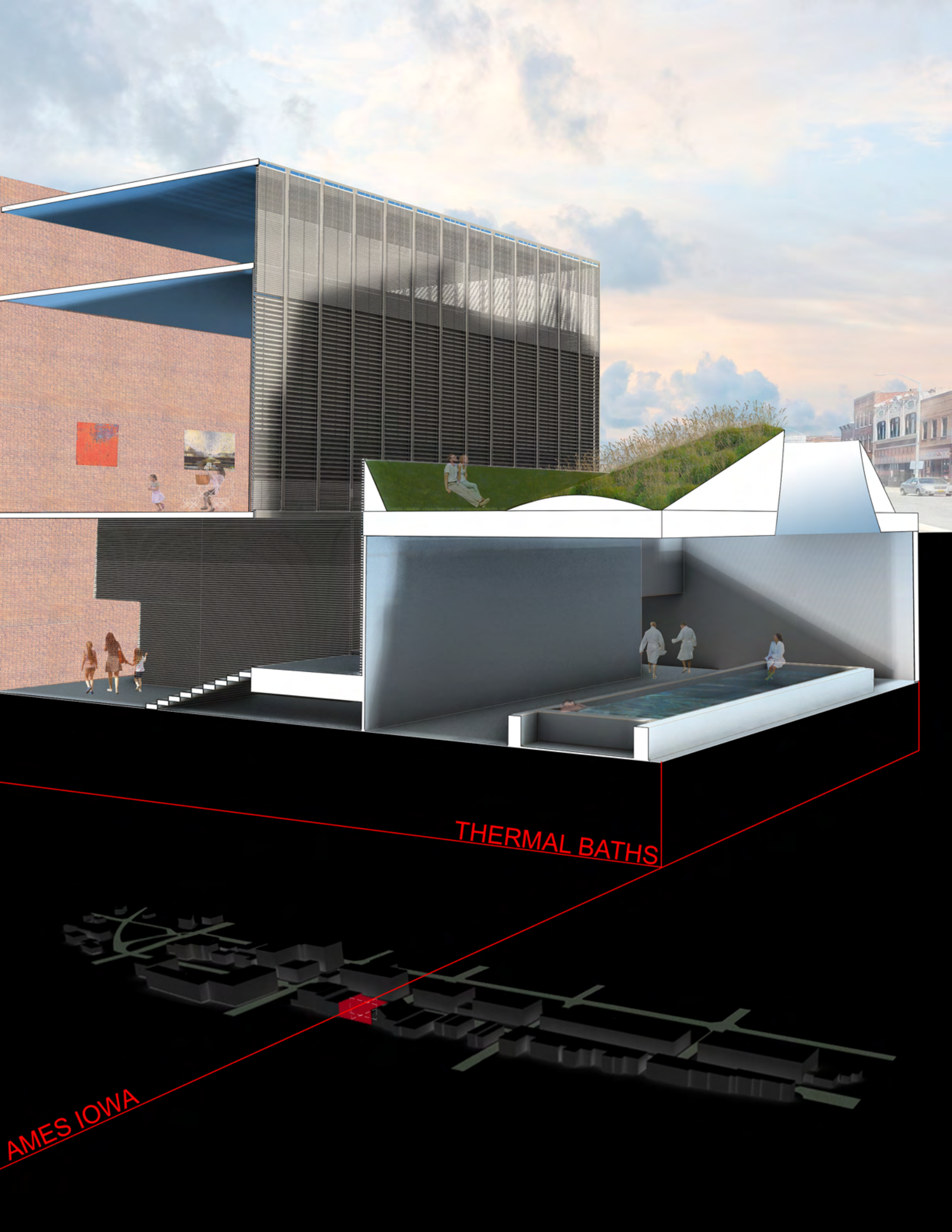

THERMAL BATHS

AMES IOWA

# [Creativity is allowing yourselves to make mistakes Architecture is knowing which ones to keep

...faced with the task of providing a space for people to interact and to serve as a forum for the exchange of knowledge and ideas. The structure's impact on the environment and sustainability was the major concern. The ensuing design was primarily based on the Indian values of living and at the same time converging a number of technologies, applied in a creative and innovative way.....

The proposed site, located at the commercial hub of NCR envisions a paradigm of modern architectural ethics by addressing global problems and facilitating evolution of ideas of this age.

**Climatic analysis:**

Air temperature in July, August and September fluctuates between 28c and 36c hence can be handled with passive cooling.  
 April, May and June has maximum solar radiation intensity. Building should be well shaded with least surface area exposed to sun. These months require active cooling as maximum air temperature ranges from 34c to 41c.  
 Air temperature drops to 7c to 9c at night in December, January and February. This period requires active cooling but daytime temperature falls within the comfort zone.  
 March, April and May require humidification as R.H drops to 18 to 25%.

**Influence of space and volume on Psychology:**

--Variation in temperature and volume along the transition spaces increases user receptivity.  
 --Interaction between the atrium and the various levels facilitates cognitive mapping of the form.  
 --Progression from formal to informal spaces promotes interactive group behavior.  
 --The circular staircase invokes a sense of accessibility in the building.

**Earth air tunnel:**

A network of underground earth air tunnels circulating cool subterranean air throughout the block. The tunnels require Effective insulation and trees providing shade.

- TUNNEL:**  
 One tunnel can condition a volume of  $(25 \times 35 \times 10) = 1$   
 Rate of air change: = 190 cubic meters/min  
 Length = 70 m  
 Diameter = 0.75 m  
 Embedded 4 m below ground level.  
 Material for the tunnel: Hume pipe
- WIND TOWER:**  
 Location of the wind tower: northwest  
 Height: 14m
- AHU:**  
 Attached to the atrium.
- SOLAR CHIMNEY:**  
 Inclined double glazed wall acts as a solar chimney.  
 Inner layer of glass is properly insulated with a low e coating.

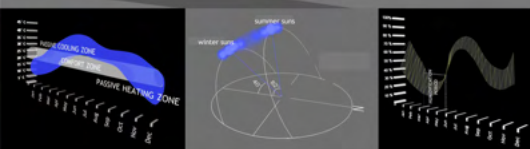

**Evolution of form:**

The solar performance of various forms of the same volume has been analyzed to evolve the ultimate profile.

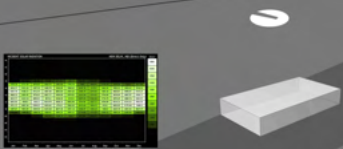

A cuboid oriented with the longer side along the east west axis. Heating is observed to be high throughout the year.

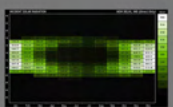

A semi cylinder with inclined walls performs exceptionally with insignificant heating in the summer and increased heating in the winter.

**Space analysis:**

--Centralized organization implies a concentrated composition with a large dominant unifying space (atrium) and respective spaces about its perimeter.  
 These spaces differ from one another in form and size in order to respond to individual requirements of function, express their relative importance, or acknowledge their surroundings.  
 The ideas that have been incorporated in the design:  
 Seminar halls, meeting and board rooms have been grouped into functional clusters.  
 --Multipurpose hall and atrium have been provided with access to exterior activity spaces.  
 --Provision of additional mechanical heating and cooling facilities in the appropriate spaces (the multipurpose hall, workshops, guest rooms) to contextually respond to modern urban requirements.  
 --The multipurpose hall and the workshop rooms are flexible in use and can be freely manipulated by providing multiple entries, prefunction spaces and facilities.  
 --Indoor fountains and water bodies increase the humidity.  
 --Major spaces can function simultaneously without hindrance to any concurrent activity. Multipurpose hall and the auditorium have zoned apart with individual auxiliary amenities.  
 --The inclined glazing along the circulation area acts as an interface between the interior and the exterior expanse.

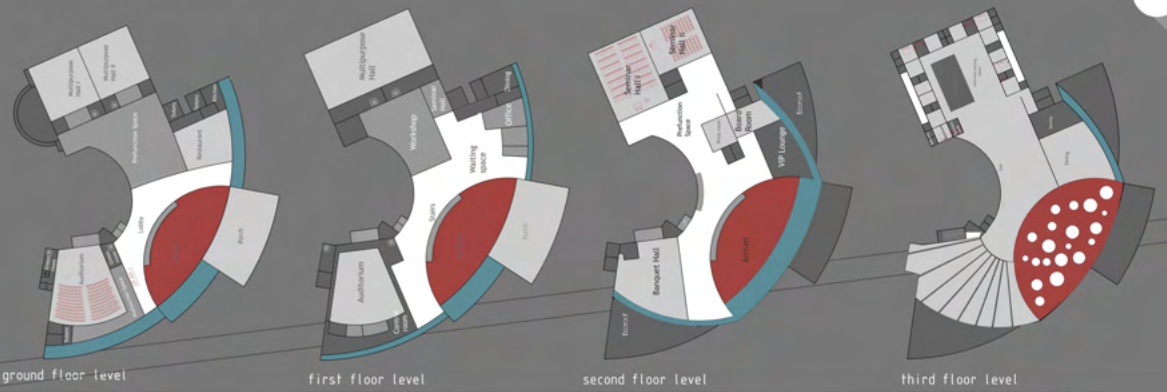
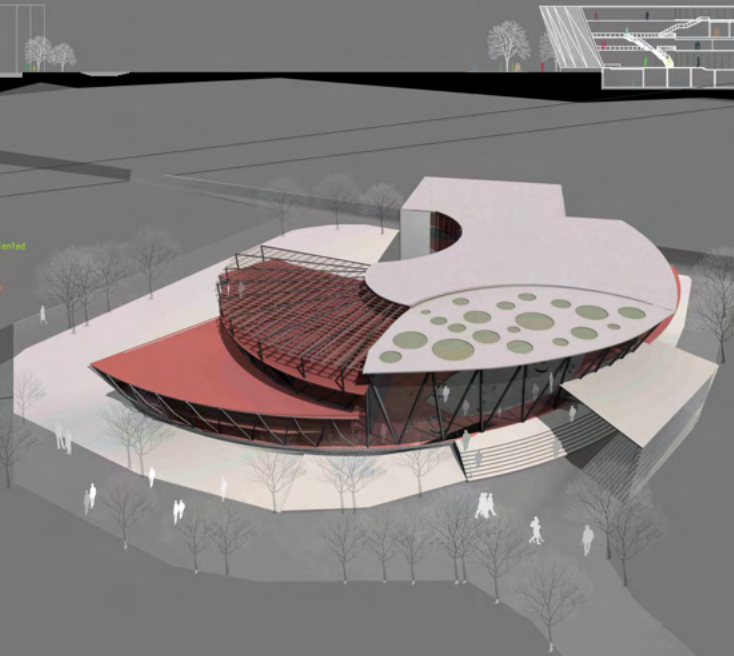
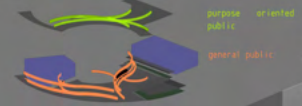



## Material analysis

AAC or autoclaved aerated concrete blocks have been used in the interior walls.

- Light weight - reduces structural load (1/4 of the weight of conventional concrete, 1/3 of clay bricks)
- Fire retardant (up to 4 hours)
- acoustic properties (STC rating of 41)
- good thermal insulator (equivalent to R-20)

Stabilized compressed earth blocks in rat trap bond have been used in the northern walls.

- Low energy input in processing and handling soil (only about 1% of the energy required to manufacture and process the same volume of cement concrete).
- made locally using local mud, thereby energy efficient.
- non-combustible with excellent fire resistance properties.

Thermochromic laminated glazing (TLG) has been used in the south and west walls.

TLG is able to sense changes in the light and adjust accordingly.

- TLG has a good UV stability, low cost, easy fabrication and no electric driving power needed.

## Energy efficiency

Creation of ac and non ac spaces

Making informal spaces non ac without compromising on comfort reduces energy consumption. These spaces have been effectively conditioned by passive technologies (earth air tunnel, form).

Volume of informal space >>>> Energy to condition this volume  
3500 cubic metres 240 kWh per day

new energy use >>>> Energy to condition the entire volume  
672 kWh per day

previous energy use ...

energy saved >>>> 36 % of air conditioning energy saved

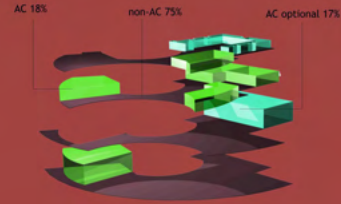

## Day lighting

Usage of artificial light in circulation spaces has been avoided. Optimum amount of daylight is permitted through the thermo chromic glazing in the atrium and inclined walls.

Fenestration area as % of floor area >>>> 165 m<sup>2</sup> / 6586 m<sup>2</sup>

Average Day Lighting factor >>>> 1.2

Illuminance required >>>> Number of lamps (18 W, 1200 lx)  
96 lx 1200

Energy for lighting (6 hrs/day) >>>> Total estimated lighting load  
130 kWh 380 kWh

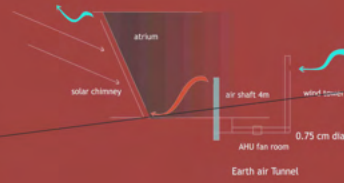

## Ecoroof

Extensive eco roofs have been used which are Easy to maintain, lightweight and use shallow soils. Mosses and Lichens and sedum are to be used as vegetation. They are the lightest vegetation, which are capable of surviving extremities of temperature.

Advantages of ecoroof:

- Provides insulation and lowers cooling and heating costs for the building.
- Green roofs are good acoustic insulators and can absorb and dampen sounds
- fire retardant plants with high water content leaves and stems (Sedums) help to create a natural fire retardant effect

## High tech facility

- Interactive screen: 8m x 4m located near the reception is embedded with fiber optic pixels which act as a filter for films and images. The user can interact with the screen and obtain information regarding the functions taking place in the centre.
- Occupancy sensors which detect motion and emission of heat, manipulate comfort environments (lighting levels, cooling) to suit user requirements.
- Video conferencing: seminar halls and press rooms are equipped with adjacent video conferencing rooms.
- Internet: wi-fi has been provided to facilitate easy, immediate internet connectivity through out the centre without the help of wired ports.
- Intra-com facilities enable interaction between the various levels and activity spaces.

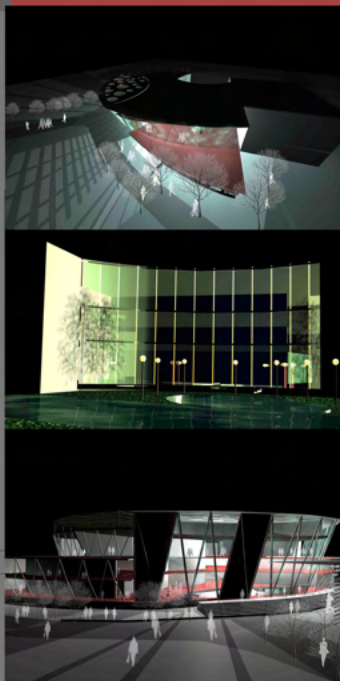

## PV panels

A grid supplementing solar plant of capacity 209 kw is situated on the roof. It consists of 160 PV panels and is capable of handling the lighting load of the top three floors independently.

The total estimated lighting load is >>> 380kwh per day (18 watt CFL lamps of 1200 lumens)

PV panels energy production >>> energy required  
= 1.25 kWh per m<sup>2</sup> = 200 kWh/day

200 kWh/1.25kwh per m<sup>2</sup>

= 0.96 m<sup>2</sup> >>> 160 m<sup>2</sup> of PV panels needed

50% of total lighting load handled.

## Rainwater harvesting

Area of roof top = 1500 SQ M  
Expected harvested rainwater = 6, 48,000 lt/year  
Total consumption of the convention centre = 14, 81,170 lt / year

Rain water satisfies 43% of requirements.

Charcoal water filter - made of gravel, sand and charcoal, gutters, conduits are made of pvc and are 10cm, 90 cm dia respectively.

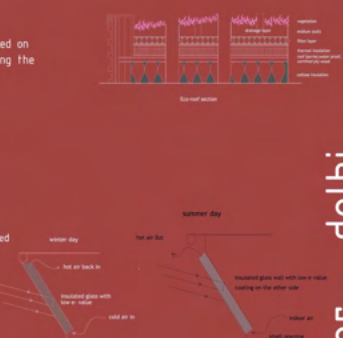

## Grey water recycling

Grey water is the water collected from the shower, bathtub, sinks and washing machine.  
Total grey water production = 1674 liters per day.  
Recycled grey water satisfies 84% of flushing needs.  
Grey water recycling saves 41 % of the water lost

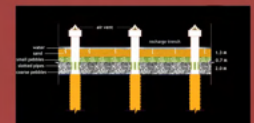

The convention center is a progressive structure which continuously adapts to the rapidly changing environment. A model for sustainability, energy efficiency and green solutions. A building which does not grow old but rather evolves with time.

convention center - delhi  
express: discover: evolve



